

# AquaSafe™ Alarm

## Installation and Operating Guidelines

The AquaSafe is a warning system which alerts the end user when there is:

- A power failure to the AquaSafe
- A high level situation in the chamber/sump
- A high level situation recorded
- A service due



## 1. CONTENTS

1. Contents.....	2
2. Product Summary .....	4
3. Site Preparation And Installation .....	4
3.1 Advisory .....	4
3.1.1 Intended Use.....	4
3.2 Installation .....	5
3.2.1 Location .....	5
3.2.2 Mounting The AquaSafe Panel .....	5
3.2.3 Mounting The Float (Mini).....	5
3.2.4 Connecting The Float To The AquaSafe (Mini).....	7
3.2.5 Mounting The Float (Sump) .....	7
3.2.6 Connecting The Float To The AquaSafe (Sump).....	10
3.2.7 Connect The AquaSafe To The Mains Electrical Supply.....	10
3.2.8 Normally Open – Normally Closed Contacts.....	12
3.3 Control Panel Operation .....	13
3.3.1 Switching On For The First Time .....	13
3.3.2 Setting The Service Interval .....	14
3.4 Buttons.....	15
3.4.1 Test Button .....	16
3.4.2 Mute Button.....	16
3.5 LED Codes And Sounds .....	17
3.5.1 Power LED (Green) .....	17
3.5.2 High Level Alarm (Red) .....	17
3.5.3 High Level Alarm Recorded (Yellow) .....	18
3.5.4 Service Due (Red) .....	18
3.6 Sounder.....	19
3.7 External Devices .....	19
3.8 Internal Battery .....	21
4. Technical Specification .....	22
5. Dimensions Of The AquaSafe Panel.....	22
5.1 Mounting Plate Template.....	22
6. Parts List.....	24
7. Spare Parts List.....	24

# AquaSafe Alarm

8. Wiring Diagram.....	25
8.1.1 Mini Float Wiring Diagram.....	25
8.1.2 Sump Float Wiring Diagram.....	26
9. Transport.....	27
10. Maintenance.....	27
11. Fault Finding.....	28
12. Health And Safety .....	29
12.1 Safety Precautions .....	29
12.2 Electrical Connections.....	29
12.3 Declarations .....	30
12.3.1 The European Union Waste Electrical And Electronic Regulations 2013 .....	30
12.3.2 Risk Of Electric Shock.....	31
12.3.3 CE Approved .....	31
13. Guarantee .....	31

# AquaSafe Alarm

## 2. PRODUCT SUMMARY

Thank you for purchasing the AquaSafe .

The AquaSafe is a warning system which alerts the end user when there is:

- A power failure to the AquaSafe
- A high level situation in the chamber/sump
- A high level situation recorded
- A service due

There is a battery incorporated within the panel to power itself in case of mains power failure.

The system is designed to activate via a mini or sump float switch, which is located inside the chamber/sump, it is set to activate higher than the activation point of the primary pump.

## 3. SITE PREPARATION AND INSTALLATION

### 3.1 ADVISORY

All products are manufactured and developed to the highest standards and assembled with precision and care. Each product has been rigorously tested. We constantly strive to develop our products to provide you with the most innovative products possible.

Please read these installation and operating guidelines carefully prior to installation. These guidelines contain important information and hazard warnings, which will enable you to install and operate your product safely, economically, and reliably.

Only qualified personnel should carry out the installation in accordance with the latest IET wiring regulations BS7671. All works should be in line with the Health and Safety at Works Act 1974.

It is important to note that these guidelines are for guidance only and it is the installer's responsibility to satisfy them-selves that the installation procedure is in accordance with good practice, this will then eliminate any potential damage to the product during or after installation.

If you are unsure on any point, then please contact Edincare Pumps technical helpdesk on **01442 211554** from 8.30am - 5.30pm, Monday to Friday or via email [info@edincare.com](mailto:info@edincare.com) for further information.

#### 3.1.1 INTENDED USE

This AquaSafe is designed for use indoors or in a suitable waterproof outdoor enclosure. Under no circumstances should the product be installed outdoors without suitable protection from both water and extreme temperatures. (Operating temperature -10°C to +40°C.)

# AquaSafe Alarm

## 3.2 INSTALLATION

### 3.2.1 LOCATION

Select a suitable location for the AquaSafe panel, taking into account that it must be located within 5m (10m if using the sump float switch) of the base of the pump chamber/sump, through the cable duct to the AquaSafe panel. It must be located in a dry area where the panel is audible and accessible by the end user. If you need to mount the panel further away from the pump chamber/sump, please contact Edincare Pumps technical helpdesk on **01442 211554** from 8.30am - 5.30pm, Monday to Friday or via email [info@edincare.com](mailto:info@edincare.com) for further information.

When siting the panel please consider the noise pollution act.

### 3.2.2 MOUNTING THE AQUASAFE PANEL

Before you mount the panel you will need to drill a hole into the panel for volt free contact(s) cabling (if required).

- The mini float switch or sump float switch uses the M16 cable gland (supplied and installed as standard).
- The power cable uses the M16 gland (supplied and installed as standard).
- For the volt free contacts, you will need to drill the appropriate diameter hole **as shown in fig.1** to add the M16 or M20 cable gland. The cable gland required would depend on the diameter of signaling cable used.

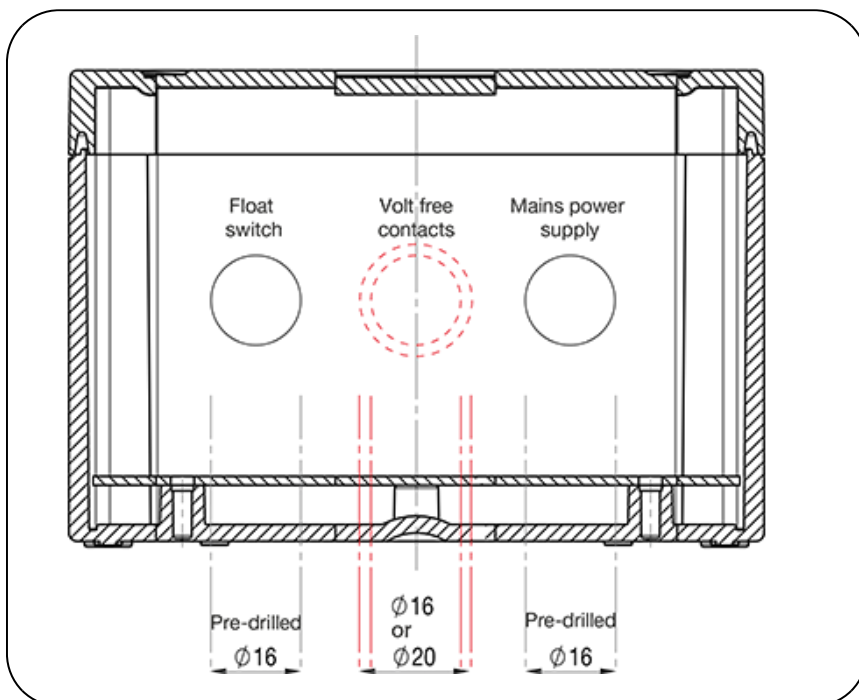

Fig.1 Drilling the mounting panel

Mount the panel to a wall or backboard using the mounting points located at the back of the panel using appropriate screws and wall plugs for the surface. **Please see fig.16** for dimensions.

### 3.2.3 MOUNTING THE FLOAT (MINI)

# AquaSafe Alarm

Please refer to the specific installation and operating guidelines for the chamber/sump when installing the float switch.

The mini float switch is supplied with a 5m cable. Should you require more than 5 metres please contact Edincare Pumps technical helpdesk on **01442 211554** from 8.30am - 5.30pm, Monday to Friday or via email [info@edincare.com](mailto:info@edincare.com) for further information.

1. Please ensure you position the mini float switch higher than the primary pump activation point contained within, **as shown in fig 2.**

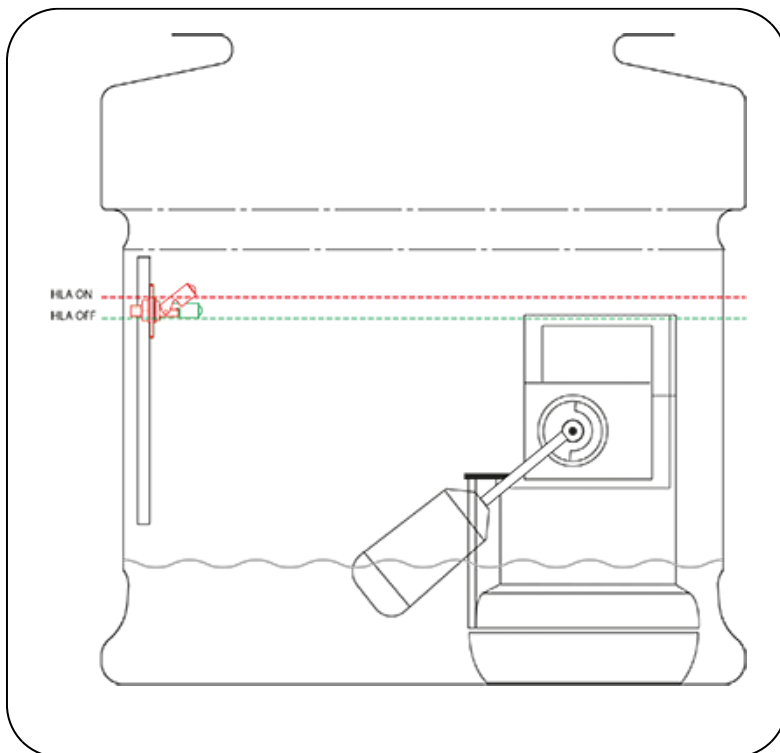

Fig.2 Mini float switch on and off positions

- 2 The mini float switch should be installed using the Edincare Pumps float bracket, the float hole is predrilled for installation of the Mini float switch.
- 3 When positioning the mini float switch insert the float cable through the green washer.
- 4 Place the mini float switch into position ensuring that the activation arm is located in the upwards position **as shown in fig 2.1.**
- 5 Insert the mini float cable through the blue plastic washer and nut and tighten fully.
- 6 Cable to be drawn through cable duct between the chamber/sump and control panel location for removal at a later date.

# AquaSafe Alarm

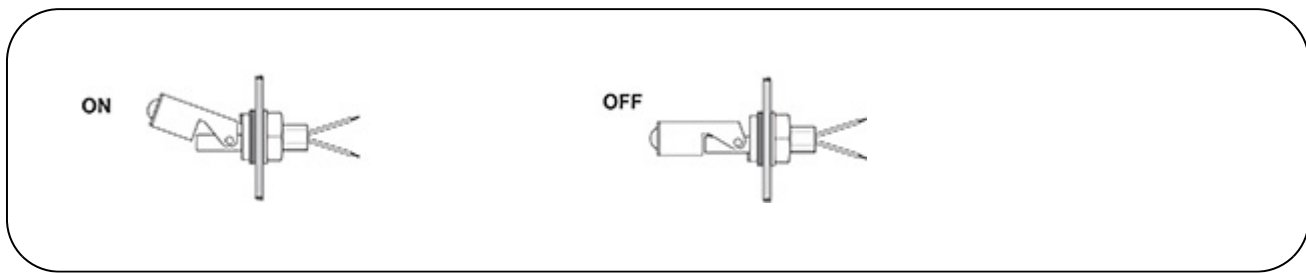

Fig. 2.1 Mini float switch on and off positions

## 3.2.4 CONNECTING THE FLOAT TO THE AQUASAFE (MINI)

1. Loosen the float switch cable gland located on the underside of the AquaSafe Alarm panel, as shown in fig.1.
2. Draw the mini float switch cable through the cable gland.
3. Connect the brown core to the positive and the blue core to the negative terminal, as shown in fig.3.

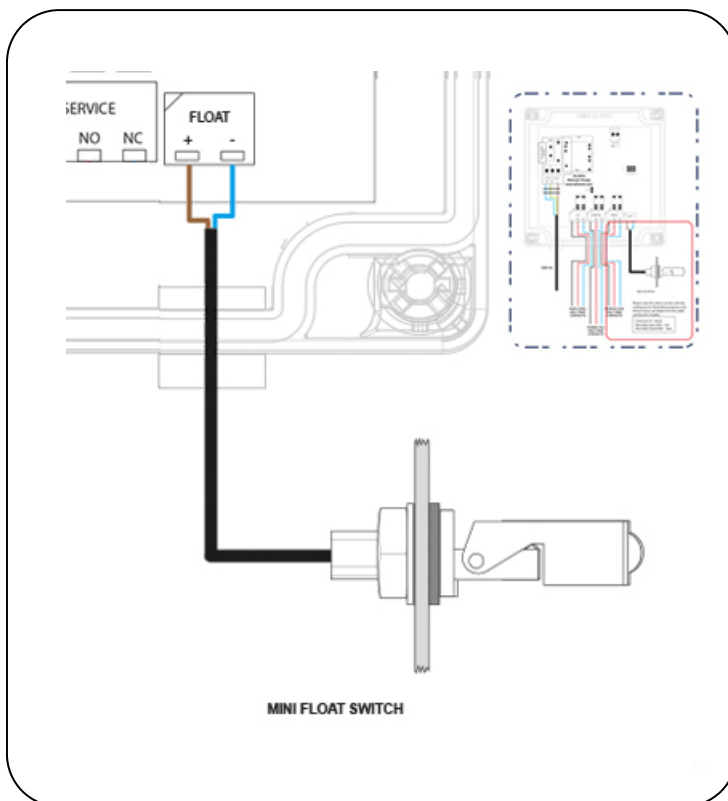

Fig.3 Connecting the Mini float switch to the AquaSafe Alarm

**(Please note, that the AquaSafe panel is factory set to a normally closed contact. The advantage is that should the mini float cable become damaged and/or disconnected the alarm will activate).**

## 3.2.5 MOUNTING THE FLOAT (SUMP)

# AquaSafe Alarm

Please refer to the specific installation and operating guidelines for the chamber/sump when installing the float switch.

The sump float switch is supplied with a 10m cable. Should you require more than 10 metres please contact Edincare Pumps technical helpdesk on **01442 211554** from 8.30am - 5.30pm, Monday to Friday or via email [info@edincare.com](mailto:info@edincare.com) for further information.

1. Please ensure you position the sump float switch higher than the primary pump activation point contained within, **as shown in 3.1**.

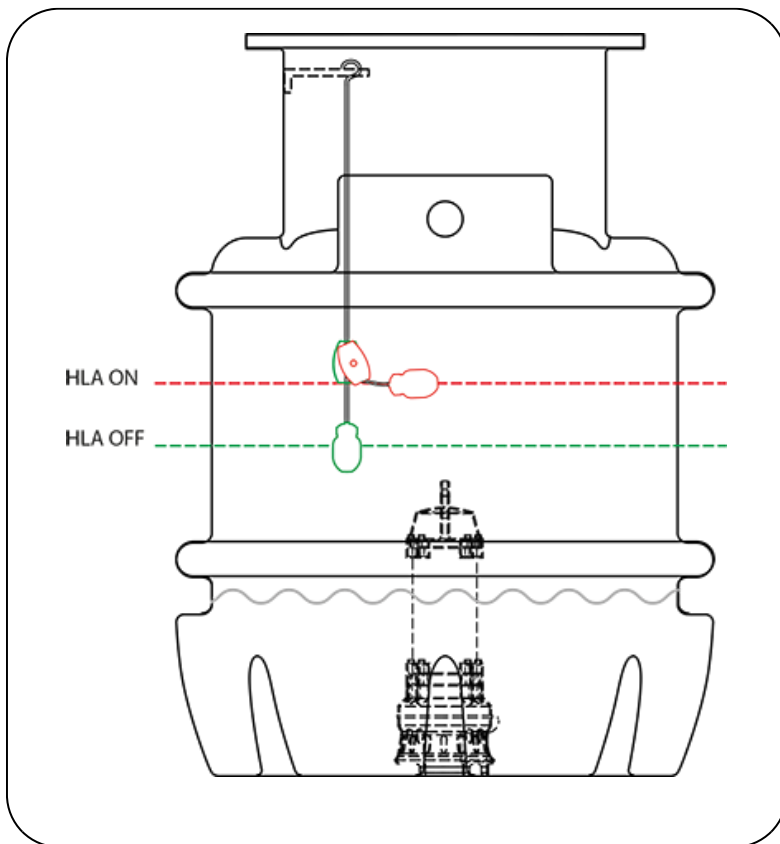

Fig. 3.1 Sump float switch on and off positions

2. Install the sump float switch cable securely. Should the sump float switch be installed using an Edincare Pumps float bracket, optional (please see the spare parts list, **as shown in section 7**) a float hole is predrilled for installation of the sump float switch.
3. Attach the counterweight approximately 70mm from the top of the float switch. You must separate the counterweight by removing the centre screw using a 6mm Allen key, once separated you will see two grooves, using the smaller of the grooves position the cable into place and put the counterweight back together ensuring the centre screw is tightened.
4. Pull the float cable through the M20 cable gland on the float bracket. Position the sump float switch higher than the primary pump activation point. Once the float has been positioned tighten the M20 gland.
5. Fix the cable into position using a cable tie to ensure the float doesn't drop down.



# AquaSafe Alarm

6. Cable to be drawn through cable duct between the chamber/sump and control panel location for removal at a later date.

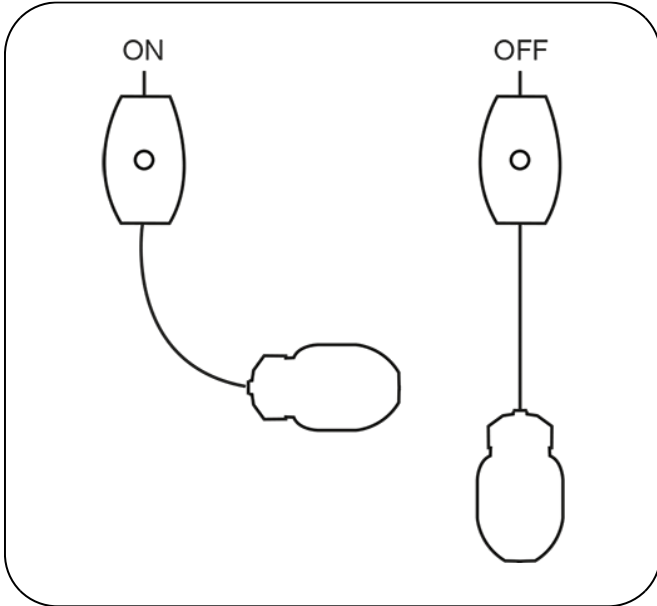

Fig 4 Sump float on and off positions

# AquaSafe Alarm

## 3.2.6 CONNECTING THE FLOAT TO THE AQUASAFE (SUMP)

1. Loosen the float switch cable gland located on the underside of the AquaSafe panel, as shown in fig.1.
2. Draw the sump float switch cable through the cable gland.
3. Connect the black core to positive and the blue core to the negative terminal, as shown in fig.5.
4. Ensure that the brown core is isolated.

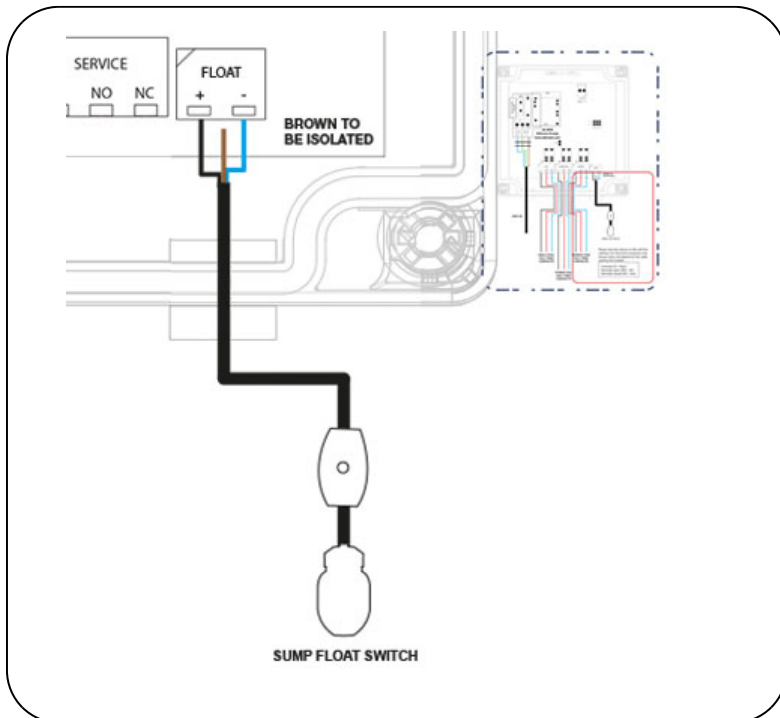

Fig.5 Connecting the sump float to the AquaSafe Alarm

**(Please note, that the AquaSafe panel is factory set to a normally closed contact. The advantage is that should the sump float cable become damaged and/or disconnected the alarm will activate).**

# AquaSafe Alarm

## 3.2.7 CONNECT THE AQUASAFE TO THE MAINS ELECTRICAL SUPPLY

The AquaSafe should be connected to the mains electrical supply by a qualified person in accordance with the Institute of Electrical Engineers Regulations with the latest IET wiring regulations - BS7671. Please take into account all the electrical information as shown in section 4 when installing the panel.

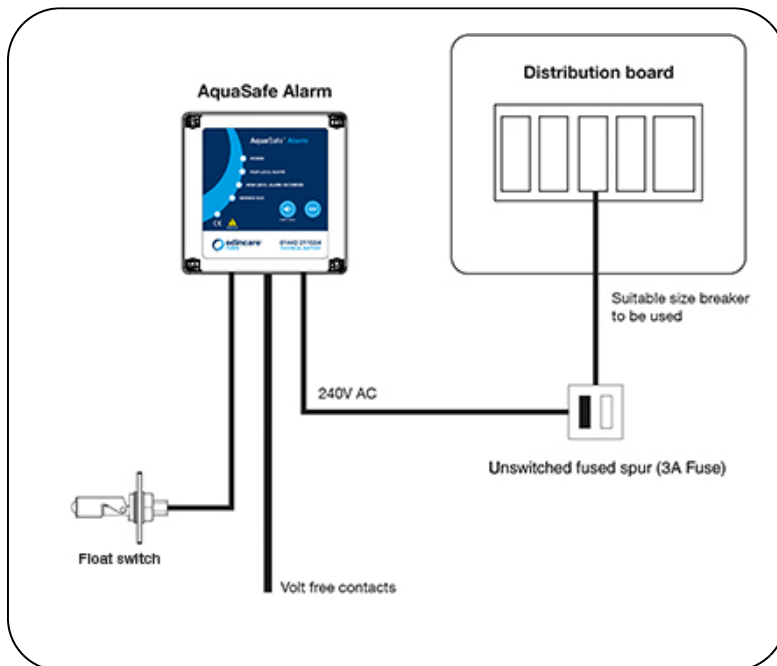

Fig.6 Connecting the AquaSafe Alarm to mains electrical supply.

**For connection to the mains electrical supply it is imperative that the AquaSafe is connected to a dedicated power supply and not via a ring main.**

The panel comes pre-installed with a 1m length of 3-core mains power cable, for connection to an un-switched fused spur (3A). The un-switched fused spur should be sited adjacent to the AquaSafe Alarm panel. Ensure that the appropriate breaker within the distribution board is clearly marked for isolation of the AquaSafe Alarm.

This work should be entrusted to a qualified electrician in accordance with the latest IET wiring regulations BS7671.

Keep the connection isolated until you are ready to test the system.

## 3.2.8 NORMALLY OPEN – NORMALLY CLOSED CONTACTS

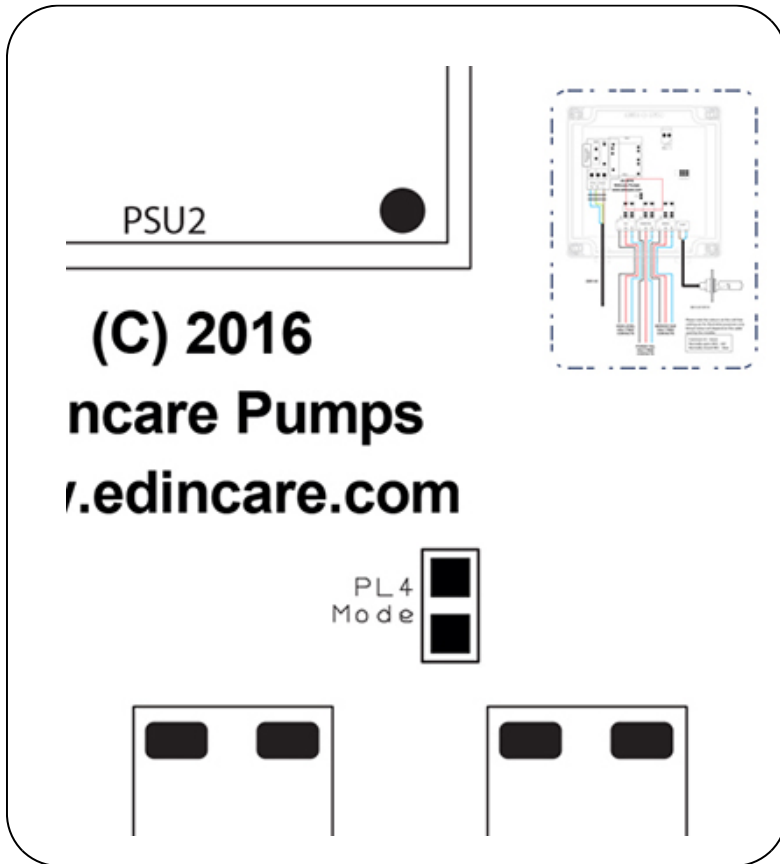

Fig. 15 Jumper settings

1. The PL4 jumper on the circuit board is set to normally closed to operate the float switch, if you need to change this to normally open please reconnect the jumper. **As shown in fig.15.**

## 3.3 CONTROL PANEL OPERATION

---

### 3.3.1 SWITCHING ON FOR THE FIRST TIME

1. Rotate panel fascia fixing screws and release the cable glands to obtain access to the inside of the panel.
2. Make float connections [as shown in 3.2.4 or 3.2.6](#)
3. Make VFC connection (if required) [as shown in section 3.7](#)
4. Connect the internal battery to the PCB, the negative core will already be connected. The positive core must be attached to the positive section of the internal battery on the base of the AquaSafe panel. Once connected it will run through its starting up sequence. The green power light will flash (and the unit will beep) until the mains power supply has been connected.
5. Replace panel fascia fixing screws and tighten the cable gland before switching on from the mains power.
6. Switch on mains electrical supply. The green power light will now be permanently lit and the system is ready to monitor.
7. Remove power to the pump/s contained within the chamber/sump and allow the water level to rise until the high level float switch is activated and activates the audio/visual alarm.
8. Reset the high level alarm recorded [as shown in section 3.5.3](#).
9. Press the 'Test' button to simulate a HLA [as shown in section 3.4.1](#).
10. Once you are ready to go live with the system please set the service interval and reset the service reminder timer, [as shown in section 3.3.2](#)

# AquaSafe Alarm

## 3.3.2 SETTING THE SERVICE INTERVAL

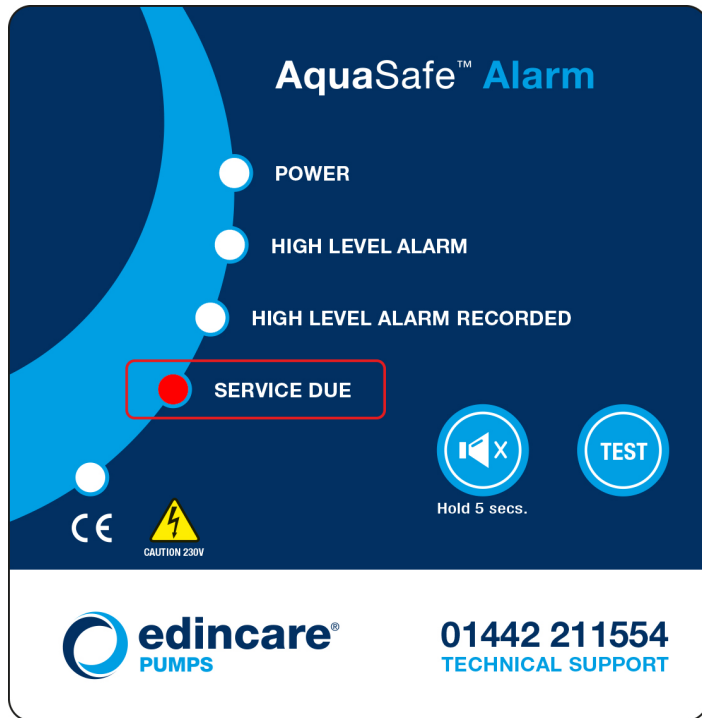

The service interval is factory set to yearly. To change to quarterly or half yearly please change the jumper settings on the PCB using the information, as shown in fig.8.



- To reset the service reminder timer, hold the mute button and press the test button five times this will reset the service reminder timer, service reminder LED and sounder.
- You will hear a number of beeps this will equal the number of months you set your service reminder too. E.g. 3 beeps quarterly, 12 beeps - yearly.

Fig.7 Setting the service intervals

# AquaSafe Alarm

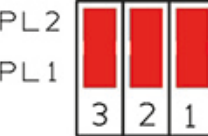
	QUARTERLY SERVICE	HALF YEARLY SERVICE	YEARLY SERVICE
			
NO.OF BEEPS	3	6	12
JUMPER 1	Not fitted	Fitted	Fitted
JUMPER 2	Fitted	Not fitted	Fitted
JUMPER3	Not fitted	Not fitted	Fitted

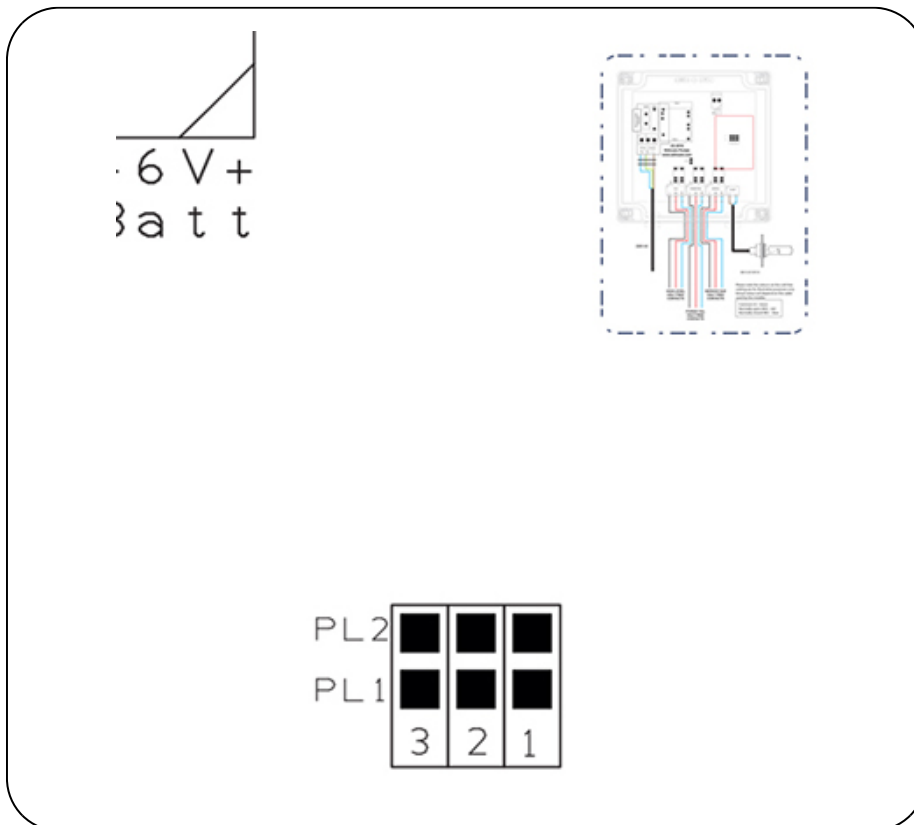

Fig.8 Setting the jumpers for the service interval

# AquaSafe Alarm

## 3.4 BUTTONS

### 3.4.1 TEST BUTTON



Fig.9 The test button

- If you hold the test button this will simulate a high level alarm.
- The audio sounder will beep and the HLA LED will flash.
- This will override the HLA audio sounder mute function if it has previously been activated.
- When the test button is released, the high level alarm recorded LED will NOT start flashing (unlike a “real” HLA).

### 3.4.2 MUTE BUTTON



Fig.10 The mute button

- To silence the audio sounder for 7 days, hold the mute button for 5 seconds - (the sounder will beep twice to confirm and the LED which was triggered will become lit continuously for the duration of the beeps).
- Please note the HLA, power fail and service reminder LED's will continue until the system returns to its normal conditions.



## 3.5 LED CODES AND SOUNDS

### 3.5.1 POWER LED (GREEN)



Fig.11 The power indicator

- **Mains power present** – continuously lit.
- **Loss of mains power running on backup battery** – flash every 2 seconds (Should the power fail condition return to normal the beeps will stop automatically.)

#### Low battery

- The system will continue to operate normally until the back-up battery discharges to a critical “low battery voltage”.
- In **low battery** mode all 4 LEDs will be sequentially flashed with a 5 second pause in between.
- During this phase, the service interval unexpired time is saved as a precaution.
- Any relay previously activated will be de-energized and no beeps will be heard.

#### Flat battery

- If mains power is not restored, the battery will further discharge and may eventually fall below a second critical value (“flat battery”).
- At this point the system will shut itself down completely.
- It will re-boot itself when the mains power eventually returns and use the unexpired service interval time previously saved.

### 3.5.2 HIGH LEVEL ALARM (RED)

# AquaSafe Alarm



Fig.12 The high level alarm indicator

- When the HLA triggers the system will beep every 2 seconds (this will trigger if there is a high level condition) once the high level condition returns to normal the beep will stop automatically and the LED will switch off.
- The HLA recorded will then flash yellow.

## 3.5.3 HIGH LEVEL ALARM RECORDED (YELLOW)



Fig.13 The high level alarm recorded indicator

- The HLA recorded will trigger once a high level alarm condition has returned to normal.
- When a HLA is recorded the light will flash every 2 seconds.
- This will continue flashing until you hold the test button and mute button together for 10 seconds. This will reset the HLA recorded LED. After 10 seconds the sounder will beep 3 times and the HLA recorded LED will stay lit, this acknowledges the command has been successfully completed.

## 3.5.4 SERVICE DUE (RED)

# AquaSafe Alarm

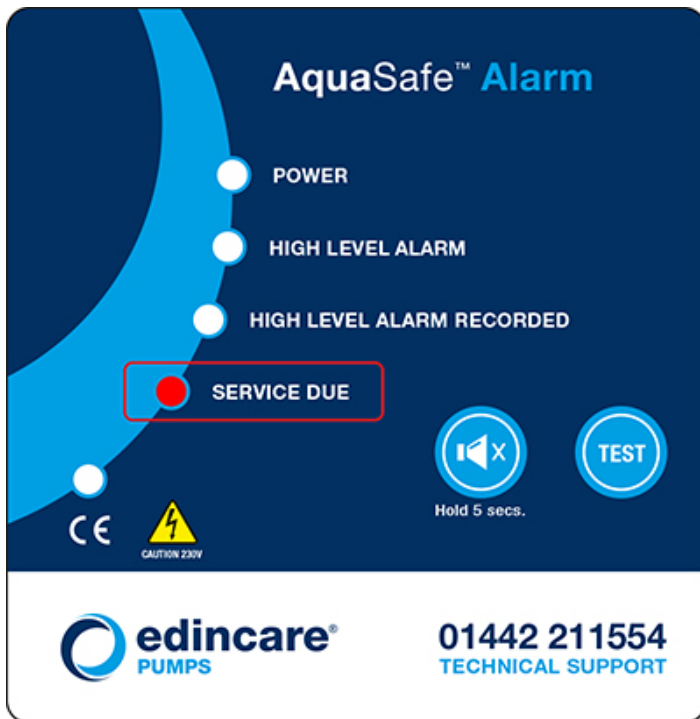

Fig.14 Service due indicator

- Service due – If a service is due the system will flash and beep every 2 seconds.
- To mute the alarm for 7 days, see mute button, as shown in fig.10.
- You will have the option to set the service reminder intervals. The service reminder intervals will be changeable via a series of jumper positions, as shown in fig.8 setting the jumpers.

## 3.6 SOUNDER

The audio sounder will be activated if a test button is pressed, a high level alarm, power fail, or service reminder condition occurs. If you wish to mute the alarm, see mute button fig.10.

# AquaSafe Alarm

## 3.7 EXTERNAL DEVICES

The AquaSafe comes complete with 3 volt free normally open (NO) normally closed (NC) terminals for connection to external devices such as a dial-out telemetry or a building management system.

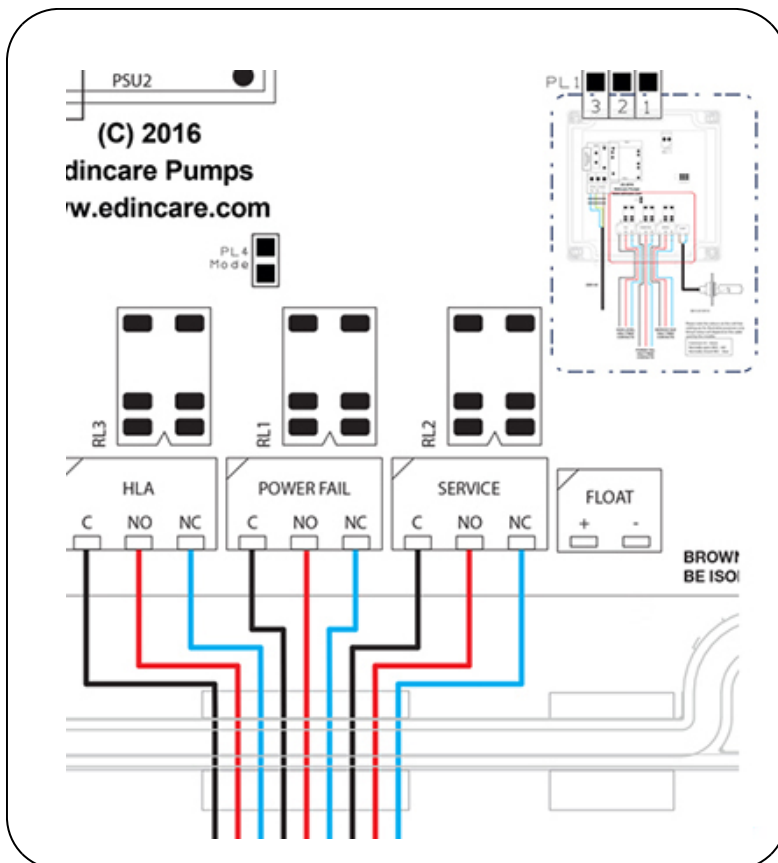

Fig 14.1 Volt free contacts

**Please note, the colours on the volt free cabling are for illustrative purposes only. Actual colour will depend on the cable used by the installer.**

The volt free contacts are intended for use of low voltage (SELV/ELV) circuits operating at max. of 1 Amp.

**High level volt free contact:-** This contact will send a signal to an external device such as a dial-out telemetry or building management system (BMS) if a high level situation occurs. There is the option of connecting to a NC or NO device depending on the receiving systems connections.

**Power fail volt free contact:-** This contact will send a signal to an external device such as a dial-out telemetry or building management system (BMS) if there is a removal of mains power to the AquaSafe occurs. There is the option of connecting to a NC or NO device depending on the receiving systems connections.

**PLEASE NOTE: This relay is normally energised when mains power is applied.**

# AquaSafe Alarm

**Service due volt free contact:-** This contact will send a signal to an external device such as a dial-out telemetry or building management system (BMS) when a service of the pump station is due. There is the option of connecting to a NC or NO device depending on the receiving systems connections.

For connection of the volt free contacts you must connect 1 core to the common terminal and 1 core to either the NC or NO contact. The connection of the NO or NC contact will depend on the connection on the receiving device.

Please see the wiring diagram [as shown in section 8](#) for further information.

## 3.8 INTERNAL BATTERY

---

The AquaSafe will operate for 24hrs without mains power subject to the battery being fully charged.

Please replace the internal battery every 2 years. This can be ordered from Edincare Pumps sales on **01442 211554** from 8.30am - 5.30pm, Monday to Friday or via email [sales@edincare.com](mailto:sales@edincare.com). See [section 7](#) for more information.

## 4. TECHNICAL SPECIFICATION

This system conforms to:

- The Low Voltage Directive, EN61010:2010.
- The EMC Directive EN55014:2006, A1 and EN55014-2:2015.

### SPECIFICATION OF THE AQUASAFE HIGH LEVEL ALARM

POWER SUPPLY	230V AC 50Hz
RATED POWER	<10VA
INTERNAL BATTERY	6V, 1.3AH
SOUND ALARM LEVEL	85dB
MAINS POWER CABLE LENGTH	1m
WEIGHT	0.5kg
MATERIAL	ABS
COLOUR	Grey
OPERATING TEMPERATURE	-10'C to +40'C

## 5. DIMENSIONS OF THE AQUASAFE PANEL

HEIGHT	122mm
WIDTH	124mm
DEPTH	85mm

# AquaSafe Alarm

## 5.1 MOUNTING PLATE TEMPLATE

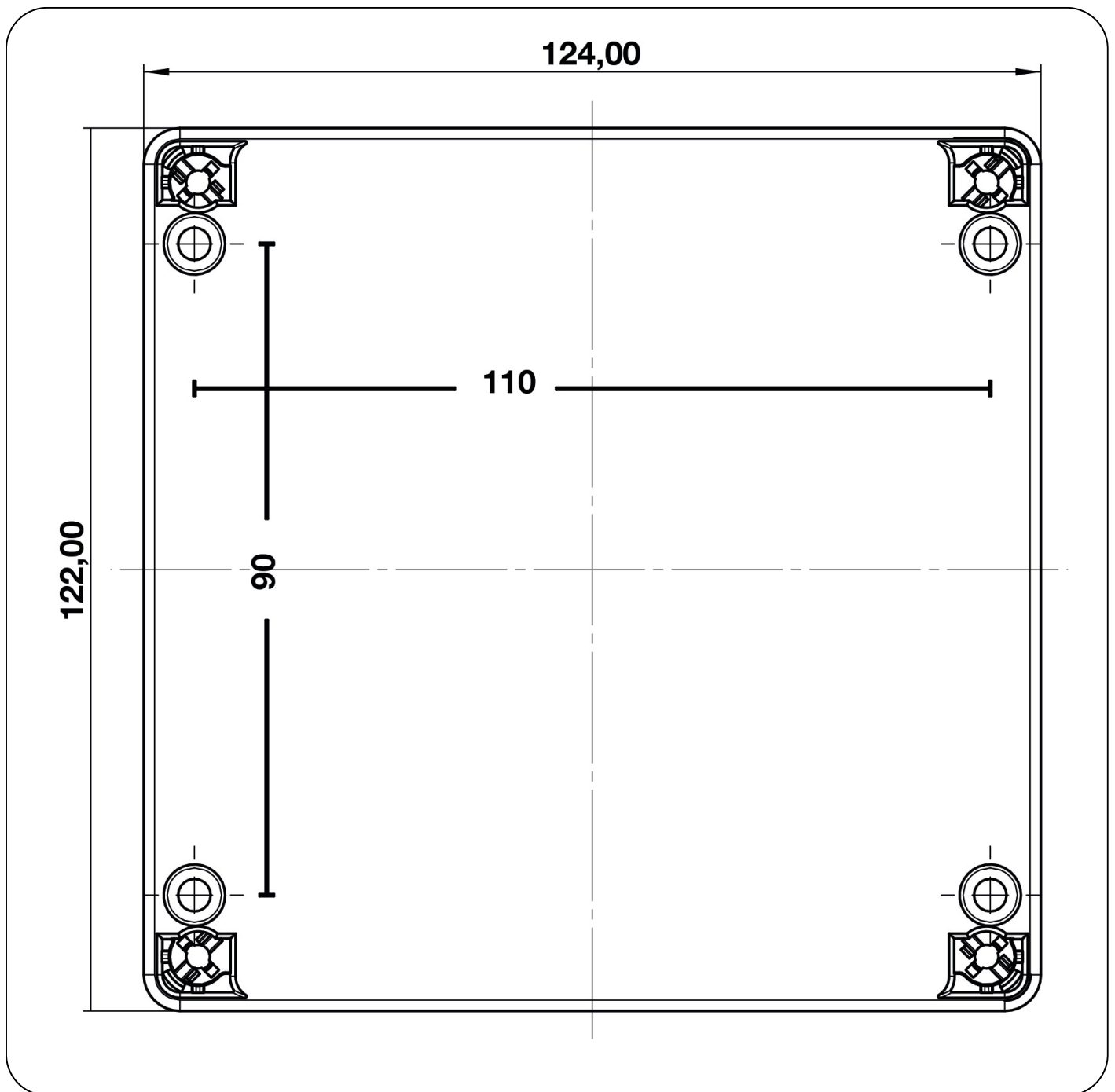

Fig.16 Mounting template

# AquaSafe Alarm

## 6. PARTS LIST

Below is a list of all the parts supplied with your AquaSafe

AquaSafe (mini)

QTY	PART NUMBER	PRODUCT NAME
1	19013	AquaSafe Panel
3	14075	16mm Black Gland
1	14035	20mm Black Gland
1	23020	Float Switch Mini
1	NA	Installation And Operating Guide

AquaSafe (sump)

QTY	PART NUMBER	PRODUCT NAME
1	19013	AquaSafe Panel
3	14075	16mm Black Gland
1	14035	20mm Black Gland
1	23019	Float Switch Sump
1	NA	Installaton And Operating Guide

## 7. SPARE PARTS LIST

AquaSafe (mini)

PART NUMBER	PRODUCT NAME
14075	16mm Black Gland
14035	20mm Black Gland
23020	Float Switch Mini
24074	3 holed float bracket
19014	Internal Battery (1.3A, 6V)

AquaSafe (sump)

PART NUMBER	PRODUCT NAME
14075	16mm Black Gland
14035	20mm Black Gland
23019	Float Switch Sump
24073	2 holed float bracket c/w backing plate
19014	Internal Battery (1.3A, 6V)



## 8. WIRING DIAGRAM

### 8.1.1 MINI FLOAT WIRING DIAGRAM

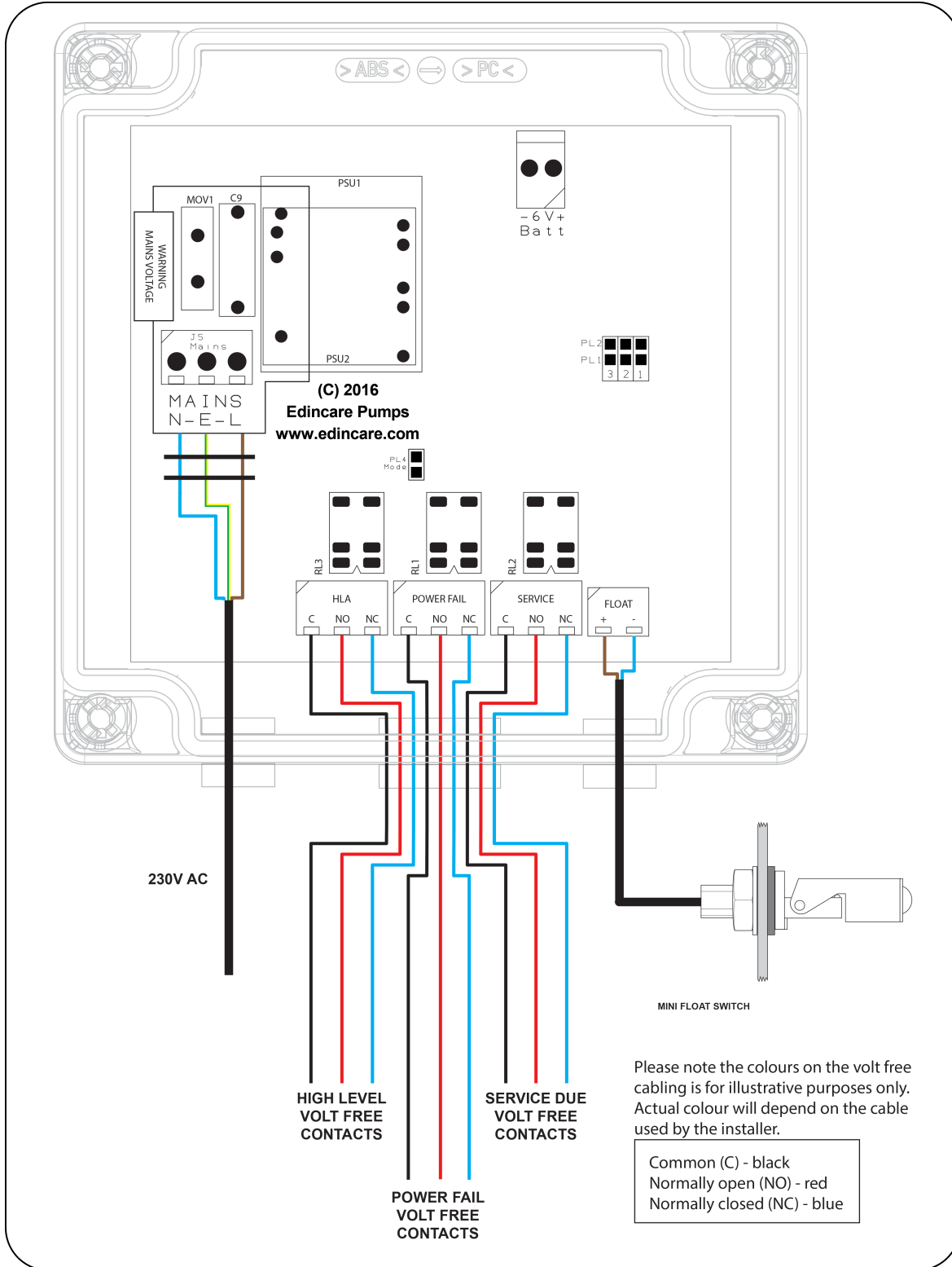

Fig.17 Mini float wiring diagrams

# AquaSafe Alarm

## 8.1.2 SUMP FLOAT WIRING DIAGRAM

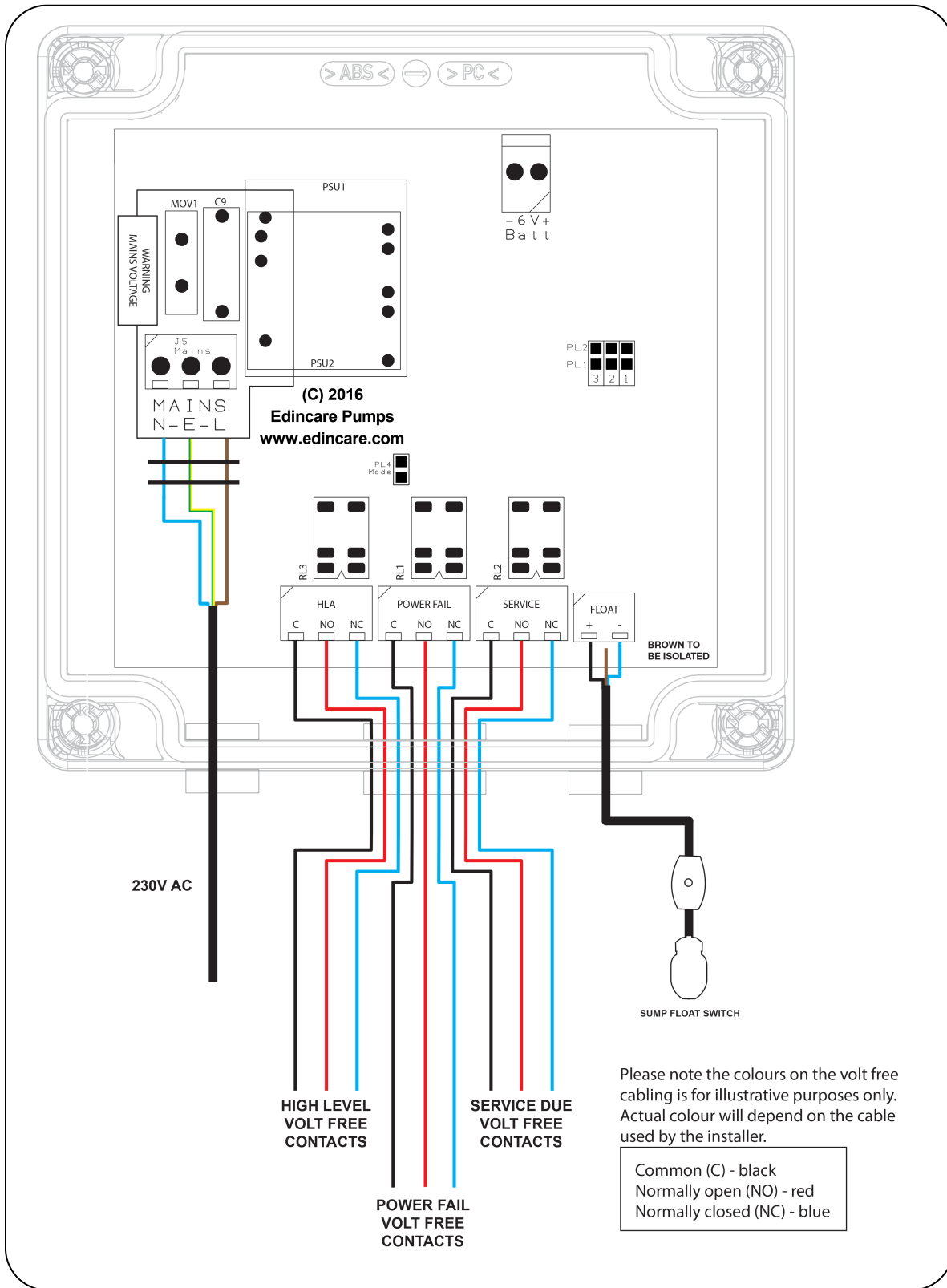

Fig.17.1 Sump float wiring diagrams

## 9. TRANSPORT

Remove the AquaSafe from its packaging and inspect for any signs of damage. Should there be any damage or missing parts this must be reported immediately (no claim will be considered after 24 hours from time of delivery). Please see the parts list as shown in section 6.

## 10. MAINTENANCE

**IMPORTANT** – All maintenance works (inspections and services) **MUST** be undertaken by a technically qualified/competent company/engineer.

Before carrying out any maintenance work the system **MUST** be completely disconnected from the mains power supply, and measures should be taken to prevent the system from being inadvertently switched back on.

When undertaking works within the chamber/sump suitable measures **MUST** be taken to ensure safe access in accordance with current safety regulations. (See section 12 health and safety).

The product should be inspected quarterly, with the following being performed;

- Operate the test button – as shown in section 3.4.1.
- Check HLA float switch – manually trigger the float switch to test the functionality of the high level alarm.
- Inspect all cables for signs of wear and tear.

When installed in conjunction with a pump system, please refer to the product installation and operating guidelines for pump station maintenance requirements.

In addition to the above it is important that the product undergoes a full service at a minimum frequency of once yearly (increased servicing frequency is subject to site and product specific details. Where a product is serving more than a single residential dwelling and/or there is a risk of flooding as a result of product failure the servicing frequency should be increased accordingly).

To arrange a service please call the Edincare Pumps aftersales helpdesk on **01442 21 1554** from 8.30am - 5.30pm, Monday to Friday or via email [aftersales@edincare.com](mailto:aftersales@edincare.com).

## 11. FAULT FINDING

PROBLEM	CAUSE	SOLUTION
High Level Alarm is constantly sounding	Damaged float cable	Repair float cable
High Level Alarm is constantly sounding	Faulty float switch	Replace float switch
High Level Alarm is constantly sounding	PL4 jumper in incorrect position	Remove jumper from PL4 to enable normally closed contact on the HLA float switch connection
High Level Alarm is constantly sounding	Pump has failed and station is at high level	Contact Edincare Pumps on 01442 211554 for further assistance
High Level Alarm is sounding before the pump activates	Float level set incorrectly	Raise the height of the HLA float switch so it activates higher than the activation point of the primary pump
No volt free output to external devices	Signal cable is connected to the incorrect NO/NC contact	Move signal cable to the correct contact
No power LED lit	No mains power to the system and the battery not connected	Check the mains power supply in from the distribution board and connect the 6V battery

If you continue to experience problems, please contact Edincare Pumps **01442 211554** from 8.30am - 5.30pm, Monday to Friday [info@edincare.com](mailto:info@edincare.com) for further information.

## 12. HEALTH AND SAFETY

Please pay attention to the following regulations when installing the product or ask your qualified electrician/distributor.

### 12.1 SAFETY PRECAUTIONS

In order to minimise the risk of accidents in connection with the service and installation work the following guidelines should be followed.

- Make sure there are no poisonous gases within the work area.
- Check the explosion risk before using electric hand tools.
- Do not ignore health hazards.
- Observe strict cleanliness.
- Bear in mind the risk of electrical accidents.
- Make sure you have a clear path of retreat.
- Use a safety helmet, safety goggles and protective shoes.
- If working at height or in confined spaces, please ensure you meet the current health and safety regulations.
- A first aid kit must be close to hand.
- No unauthorised modifications should be made.
- Operation should be in accordance with this guide.

### 12.2 ELECTRICAL CONNECTIONS

Anyone carrying out electrical work must ensure that reasonable provision has been made in the design and installation of the electrical installations in order to protect any persons who might use, maintain or alter the electrical installation of that dwelling from fire and injury, including electric shock, this should be done in accordance with the latest IET wiring regulations BS7671.

- The following works should only be done by qualified and authorized electricians.
- Edincare disclaims all responsibility for work done by untrained or/and unauthorized personnel.
- Heed operating voltage (as shown in section 4 and any additional labels)
- Take out the main fuses to isolate the mains power supply from the control system before repairs or any other works and ensure it cannot be energized again.
- Before starting check the efficiency of the protective arrangements of the pump and the monitoring equipment. Failure to heed this warning may cause a lethal accident.
- Do not put the lead ends into water! Irruption of water may cause malfunctions.
- If persons are likely to come into physical contact with the pump or pumped media, the earthed (grounded) socket must have an additional connection to an earth (ground) fault protection device (GFI). (See earthing)
- Connection only to a mains power supply installed in accordance to the local regulations. Please consider the voltage drop of long supply cables.

# AquaSafe Alarm

- Replace the cable if the cable jacket is damaged. Do not pinch the cable or pull it around sharp bends.
- Always install the control system in a dry and well-ventilated room above the back pressure level. Never install the control system within the chamber/sump.

## Earthing

- For safety reasons, the earth conductor should be approximately 50mm (2") longer than the phase conductors. If the motor cable is jerked loose by mistake, the earth conductor should be the last conductor to come loose from the first terminal. This applies to both ends of the cable. Ensure the correct earthing of the pump and control system.

## 12.3 DECLARATIONS

---

### 12.3.1 THE EUROPEAN UNION WASTE ELECTRICAL AND ELECTRONIC REGULATIONS 2013



This pcb assembly is classified as Electrical or Electronic equipment and should not be disposed of in normal domestic or commercial waste. The mandatory crossed out wheeled bin symbol (see above) on the product indicates that the product shall not be mixed or disposed of in household or commercial waste. Under the WEEE Directive, the equipment should be recycled using the best possible techniques to minimise environmental impact and avoid unnecessary landfill.

For further information, visit,- <http://www.legislation.gov.uk/ukxi/2013/3113/contents/made>

# AquaSafe Alarm

## 12.3.2 RISK OF ELECTRIC SHOCK



Caution 230V

**DO NOT OPEN THIS UNIT IF NOT QUALIFIED TO DO SO**

To reduce the risk of electric shock, do not remove cover. No user-serviceable parts inside. Refer servicing to qualified service personnel.

**Disconnect from mains before removing cover.**

## 12.3.3 CE APPROVED



The Product complies with the relevant sections of,-

- The Low Voltage Directive, EN61010:2010, and
- The EMC Directive EN55014:2006, A1 and EN55014-2:201513.

## 13. GUARANTEE

12-month component guarantee (please refer to our condition of sale for further information).

If within the guarantee period of a product any defect is discovered in respect of workmanship, construction or material, we will make good the defect or replace the defective part at our expense inside normal working hours at the company's premises providing, written notice is given immediately the defect is discovered and that, if required by us, the part or complete system is returned to the company's premises carriage paid. Spares or repaired parts are delivered ex works exclusive of fitting.

The guarantee does not apply to defects caused by incorrect installation, abnormal conditions of working, accidents, misuse or neglects. Our responsibility is in all cases limited to the cost of making good the defect or replacing the defective part at the company's premises inside normal working hours. The company excludes all liability for any consequential or other damage or losses which may occur.

Supplied in conjunction with 



01403 210204



info@safeguardeurope.com



linkedin.com/company/safeguard-europe



01403 217529



www.http://  
www.safeguardeurope.com



twitter.com/SafeguardEurope

Safeguard Europe Limited, Redkiln Close, Horsham, West Sussex, UK, RH13 5QL